

GLASS CRUSHER

MODEL

620



- ▶ Rated capacity: 3 to 4 tons per hour
- ▶ Crushes up to and including one gallon containers
- ▶ Processes full or partially filled containers
- ▶ Factory-direct parts and service

A high volume glass crusher designed for long life and trouble-free operation. This model is capable of handling full or empty bottles. Conveyor designed with side flanges on belt and cover rails to contain material. This feature has proven to greatly extend the life of the belt, eliminating some costly routine maintenance found on other crushers.

MODEL

620

SPECIFICATIONS

- ▶ Machine constructed of heavy gauge steel
- ▶ Designed for easy maintenance and upkeep
- ▶ Replaceable crushing chamber
- ▶ Reduces volume by 80%
- ▶ 1/2 HP crusher motor
- ▶ 1/2 HP conveyor motor
- ▶ Crushed glass weight = 80 lbs./cu. ft.
- ▶ 16" wide conveyor bed
- ▶ Features self-cleaning tail pulley
- ▶ Replaceable rubber discharge shroud
- ▶ Hardened replaceable crusher bar
- ▶ Side flange belt

DIMENSIONAL INFORMATION

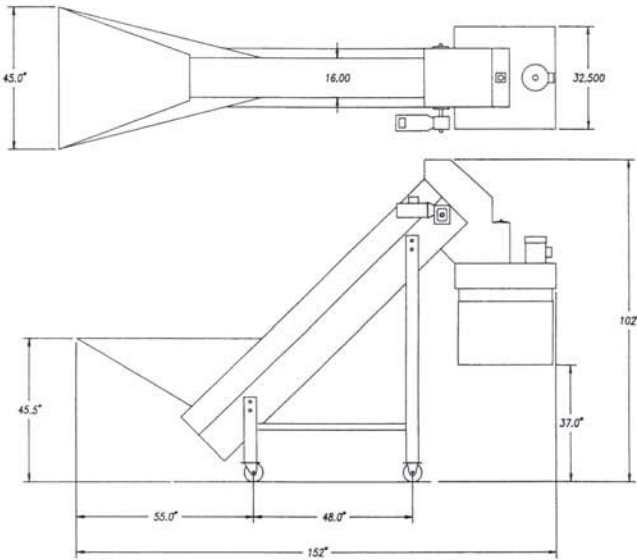

OVERALL DIMENSIONS

Length: 12'8"
Width: 45"
Height: 8'6"
Weight: 1,188 lbs.