

# FLATTENER BLOWER

MODEL **500**

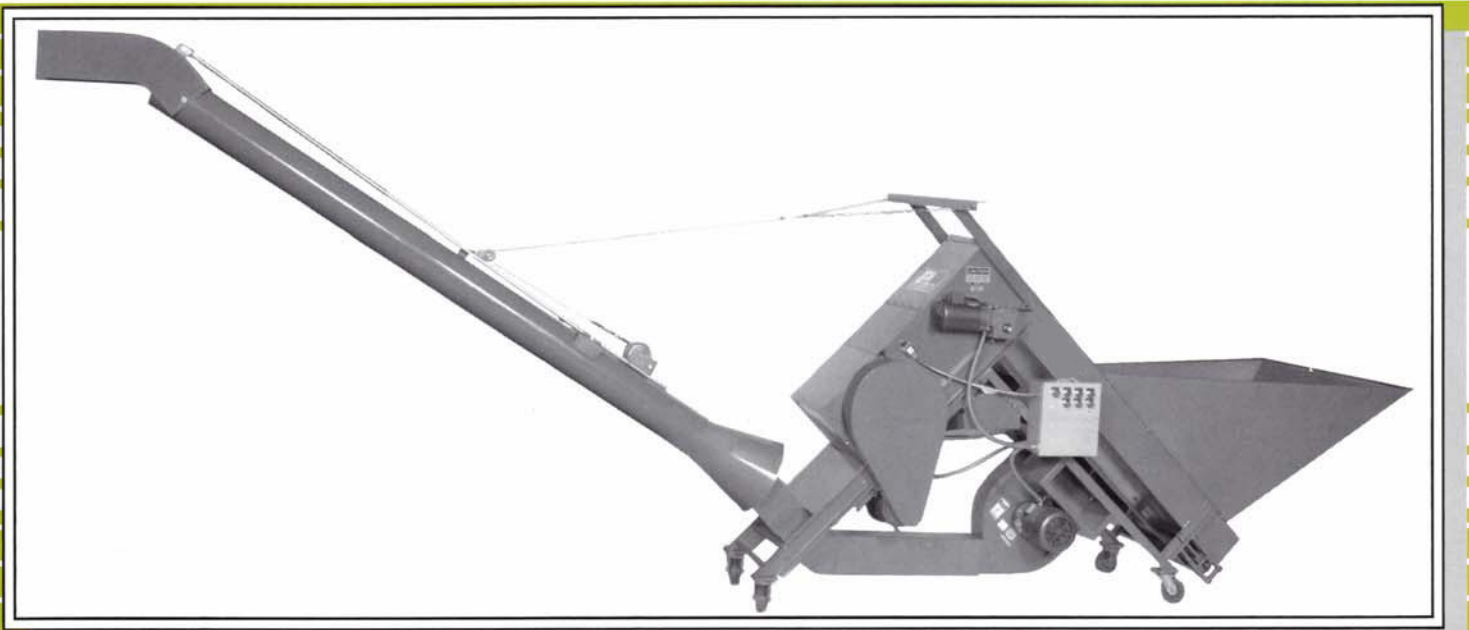

- ▶ Rated Capacity: 1900 lbs. per hour
- ▶ Factory direct parts and service
- ▶ Safety engineered throughout

Model 500 is designed to separate aluminum from steel and bi-metal cans, crush and blow aluminum cans into trailers, rolloffs, or any type of holding container. Machine is equipped with replaceable drum cleats, spring loaded crusher plate, casters for easy mobility, magnetic head pulley, and high efficiency blower.

## GENERAL SPECIFICATIONS

- ▶ 5 HP crusher motor
- ▶ 7.5 HP blower motor
- ▶ 1/3 HP conveyor motor
- ▶ 8" diameter magnetic head pulley
- ▶ Density up to 7 lbs. per cubic ft.
- ▶ 12' long 8" diameter adjustable delivery tube
- ▶ Dirt and moisture screen in bottom of infeed hopper
- ▶ Steel can reject chute, adjustable for left or right hand discharge
- ▶ 18" wide cleated conveyor belt
- ▶ Continuous feed
- ▶ 5" casters

MODEL  
**500**



## ▶ DIMENSIONAL INFORMATION

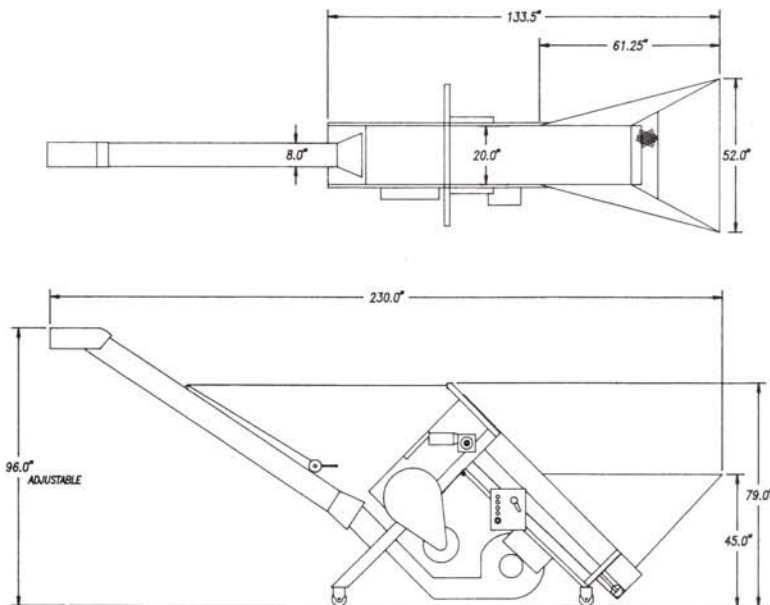

### 1 Year Written Warranty

All brand equipment carries a warranty on workmanship and materials, provided equipment is used for its intended use and maintained properly.

We reserve the right to repair or replace parts at our option. Ask for further details.

also reserves the right to improve or alter products without prior notice.