

# COMPACTORS INC.

XM Bag Packer Series

MODEL

XM-40

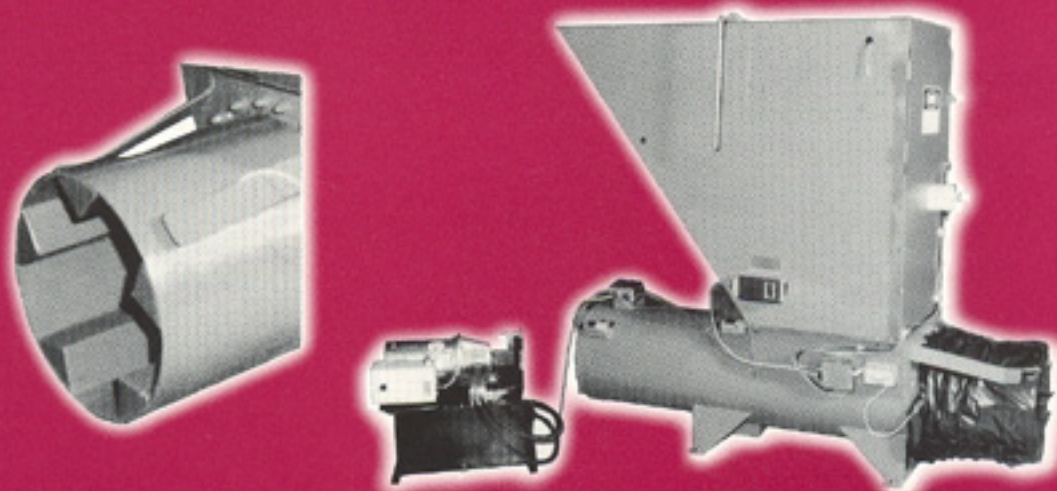

## Overview

**Application:** The XM-40 is an extrusion-type compactor, suitable for all chute fed applications of residential type refuse. An extremely rugged machine, trash can be compacted into single or multiple bag systems. Using multi-bag operation, it can produce ten bags of compacted refuse without attention, an ideal solution to time periods when no maintenance personnel are available. The extruded tube of refuse is simply separated into individual bags for removal.

**2 Models to Choose From:** The XM Series consists of the Model XM-40 and the XM-40M. The Model XM-40 is the full size machine, while the XM-40M is slightly smaller for applications where a standard machine will not fit.

## Specifications

**General Description:** A hydraulically operated concentric ram compactor utilizing the extrusion principle. Refuse is forced through the nose of the compactor which contains a unique set of restrictors. The compactor body and compaction chamber are rugged and durable. They are tubular in shape, forming one continuous body of high strength 3/8" steel plate. The ram is similarly constructed of 1/4" plate with a compaction face of 1" plate. The hopper is constructed of a 14 gauge steel, with a 1/4" impact plate.

**Features:** The XM-40 is an extremely practical, low-priced, single or multi-bag compactor. A photoelectric sensor starts the compaction cycle when refuse enters the hopper and turns the machine off when hopper is empty. Compactor automatically shuts off to prevent damage from an oversized or uncrushable object. A service access door is provided on the front of the hopper, equipped with an electrically interlocked safety switch which prevents the machine from operating if the access door is open.

MODEL

## XM Bag Packer Series

XM-40

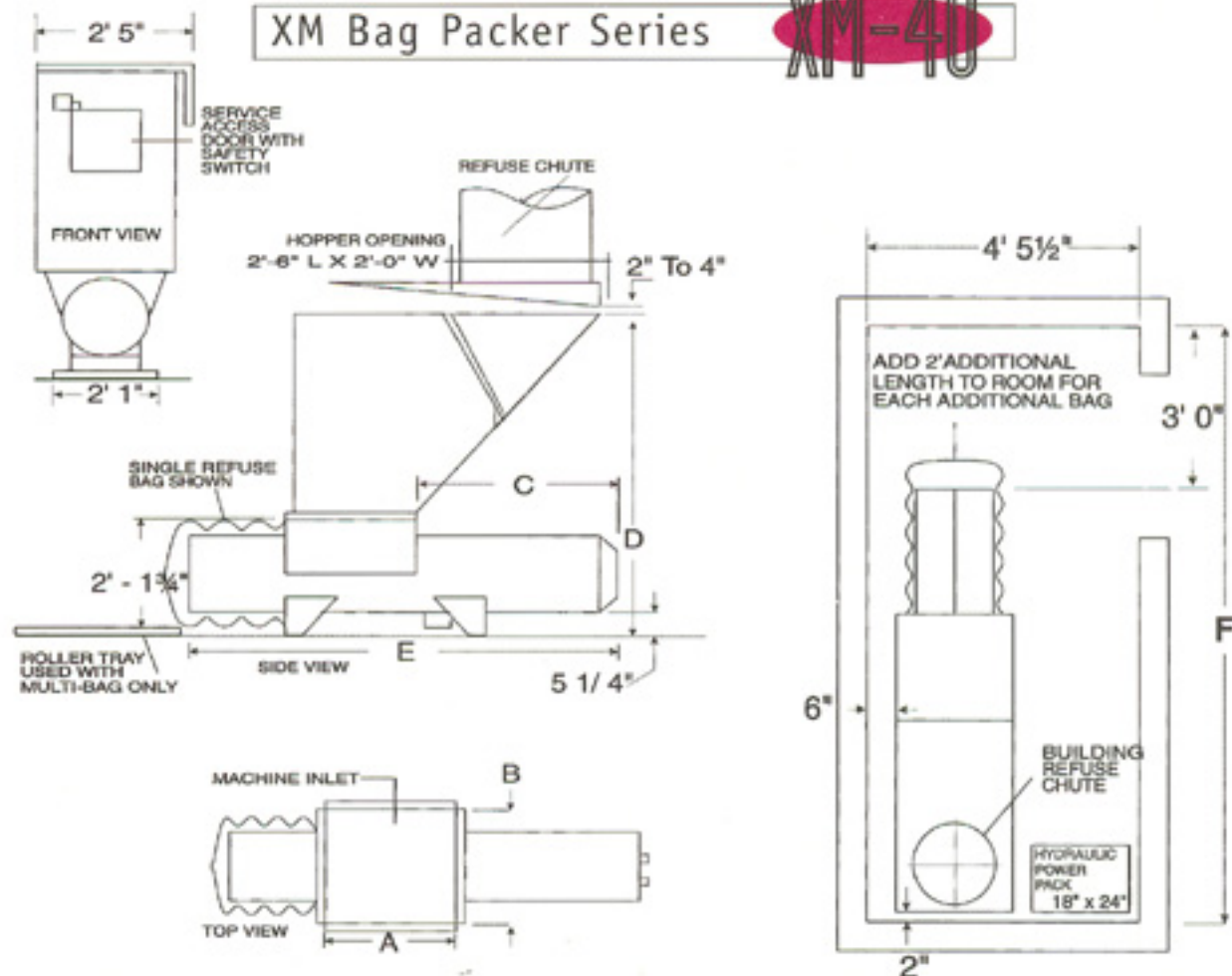

Dimensions	A	B	C	D	E	F
XM-40	2'-0"	2'-0"	3'-0"	5'-10-1/4"	6'-8"	10'- 3-1/2"
XM-40M	1'- 9"	2'- 0"	2'-7-1/2"	5'-3-3/4"	5'- 10-1/2"	9'-5"

**Hydraulic:** A prepackaged and assembled power unit is provided. Components are rated at 3000 psi, but operate at an average pressure of 1000 psi. Only quality components are used to provide long life and low maintenance. Both models are provided with a 4" bore, 2" rod cylinder, providing 38,000 lb. of compaction force. Ram face pressure (max.) for both the XM-40 and the XM-40M is 165 psi. Cycle time for the XM-40 is 45 seconds, 35 seconds for the XM-40M.

**Electrical:** 208 volts, 60 Hz, 3 phase, 4 wire, 5 HP motor operating at 1725 rpm, 15 amps. Furnished with motor starter and 115 volt control and logic circuit.

**Finish:** Painted with a blue industrial grade enamel to provide protection from deterioration.

**Options:** An automatic deodorizer is available, which is a battery operated dispenser with aerosol cans which operate on selected time intervals. Heavy plastic bags are also available, either single or multi-bags. A roller tray is also available for multi-bag systems.

Specifications Subject To Change Without Notice

## COMPACTORS INC.

Post Office Box 5918 • Hilton Head Island, South Carolina 29938

Tel: 843-686-5503 or 800-423-4003 • Fax: 843-686-3290 • Email: mjp2150@aol.com

or visit our Web site at [www.compactorsinc.com](http://www.compactorsinc.com)