



Vertical Baler - V630CC

Our standard high density baler has an economical yet dependable design.

The V630CC baler is configured for generating mill size, marketable bales of corrugated materials (OCC) while controlling equipment cost.

This model is ideal for Retailers, Grocery Stores, Drug Stores, and other organizations that recycle OCC.



SPECIFICATIONS	
PERFORMANCE	
Nominal Bale Size	60" x 30" x 48"
Bale Weight	Up to 1000 lbs OCC
Bale Volume	50 cu.ft.
No. of Bale Tie Slots	6
Compact Force lbs. - Normal/Maximum	56,548/62,202
Platen Pressure	34 PSI
Average Cycle Time	48 Seconds
Loading Height	49.50"
Ejector System	Semi-Automatic
HYDRAULIC/ELECTRICAL	
Motor HP	10
Voltage 3 Phase	208, 230, 480
Pump GPM	10.5
Normal System Pressure PSI	2000
Max. System Pressure PSI	2200
Cylinder Bore	6"
Hydraulic Tank-Capacity Gallons	22

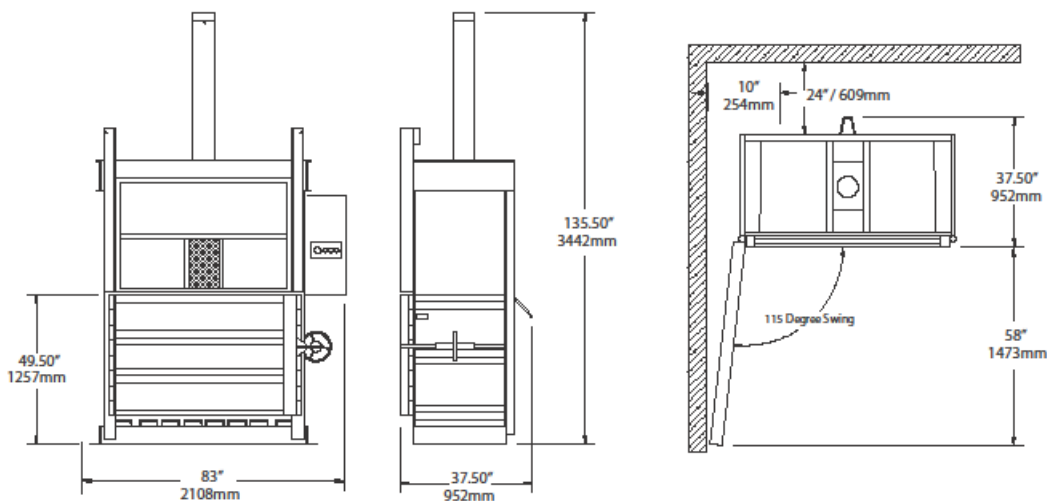

Includes:
Hydraulic Oil &
Starter Bundle of Wire

Due to continual product improvement Compactors Inc. reserves the right to change specifications without notice. The information and pictures used in the document are for illustrative purposes only.

Compactors Inc. equipment is ETL/CSA certified with UL listed controls and meets or exceeds ANSI standard Z245.5.

Printed on recycled paper
M-01102011